

S2A

SIGNAL To CAN CONVERTER

User Manual



memorized on other form without the written consent of GET by Athena.
GET has the right to change without notice the content of this manual.

INDEX:

1	ABOUT THIS PRODUCT	5
2	INSTALLATION	5
2.1	PRECAUTION	5
2.2	CONNECTING TO THE CAN BUS	6
2.2.1	CAN BUS TERMINATION	6
3	SYSTEM BEHAVIOR	7
3.1	LEDs BEHAVIOUR	7
3.2	STANDARD CAN CONFIGURATION	7
4	TECHNICAL DATA	9
4.1	SPECIFICATIONS	9
4.2	DIMENSIONS	10
4.3	HARNESS	10
4.4	CONNECTORS PINOUT	11
4.4.1	MAIN CONNECTOR	11
4.4.2	CAN CONNECTOR	11
4.4.3	EXP-1 CONNECTOR	12
4.4.4	EXP-2 CONNECTOR	12
4.4.5	BINDER CONNECTORS (AN1, AN2, AN3, AN4 INPUTS)	12
4.5	OPTIONALS CABLE (SOLD SEPARATELY)	13
4.5.1	GL-196-AN (AN5, AN6, AN7, AN8 INPUTS)	13
4.5.2	GL-196-IC (IC1, IC2, IC3, IC4 INPUTS)	14
5	MOST COMMON SENSORS/SEGNSALS CLASSIFICATION	15
6	WIRING EXAMPLES	16
6.1	STAND-ALONE CONNECTION	16
6.2	SL1 - S2A CONNNECTION	17
6.3	SL1 – ECU GET - S2A CONNECTION	18
6.4	SL1 - S2A - D30 DASH CONNECTION	19
7	GLOSSARY	20

Dear customer,

thank you for choosing a **GET DATA ACQUISITION AND ANALYSIS SYSTEMS** by **Athena**.

We are sure that our passion and experience will help you to express successfully in all competitions, we ask you to carefully read this user manual. We are confident that this will help you in the use of you new product **GET** by **Athena**.

1 ABOUT THIS PRODUCT

S2A device is specially designed to convert analog (e.g. temperature, position, pressure sensors) and frequency (e.g. speed sensors and tacho pulses) signals to CAN bus messages. One or more S2As can be connected to the same bus at same time (only if correctly configured).

S2A is an ideal integration and expansion for SL1 family dataloggers.

S2A combines:

- 8 analog sensor inputs (AN).
- 4 frequency sensor inputs (IC).
- 5V regulated power supply (AN inputs only)
- Power supply output (IC inputs only)
- 1 CAN communication port (CAN 2.0A/B)
- 1 serial port (device configuration only)
- CAN terminator connector

2 INSTALLATION

S2A can be easily installed.

Make sure that your device is compliant to the connected CAN bus speed and that its IDs don't overlaps existing messages: if that happened S2A must be reconfigured.

You need also to respect general electrical connection rules of course.

Both power inlet and CAN signal are in device **MAIN** and **CAN** connectors.

2.1 PRECAUTION

Before install the device onto a vehicle please observe the following rules:

- Work in a friendly environment (e.g. enough working space).
- Disconnect battery .
- Put all removed vehicle parts in a safe place avoiding damaging them.
- Install system when engine is cold: during the installation you could be in contact with hot parts.
- Take care to connectors and wirings (avoid sharp surfaces contact or hot parts).
- Keep washers, bolts and nuts in a safe place during **SL1** installation.
- During installation avoid that any part installed interfere with driving parts or with the driver.



WARNING: WRONG INSTALLATION MAY CAUSE INJURY PEOPLE

2.2 CONNECTING TO THE CAN BUS

CAN bus type, speed and message IDs can be considered before connecting S2A.

Standard S2A configuration is:

Bus Type: High-Speed

Bus speed: 1Mb/s

Message IDs: 0x90,0x91,0x93

Remember that CAN bus needs to be terminated properly (engaged the connector cap of CAN harness – which includes a 120Ω resistor- you can terminate the bus).

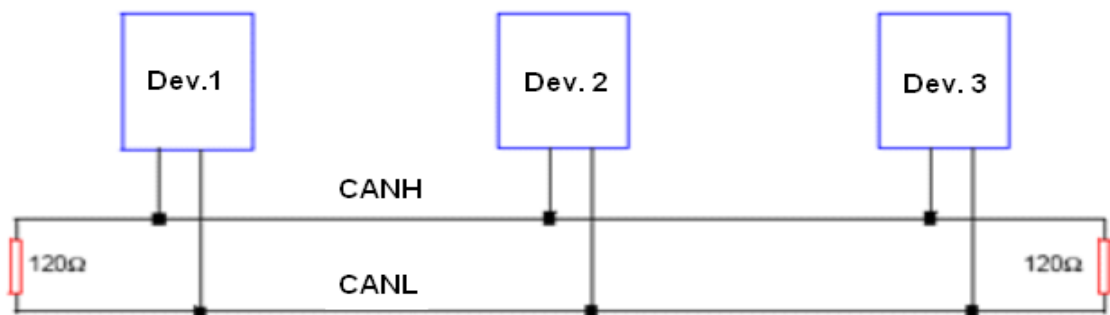

More than one S2A devices can be connected by engaging the first device CAN connector to the MAIN connector of the next one: **IN THIS CASE ALL DEVICES NEED TO HAVE SAME BUS SPEED BUT DIFFERENT MESSAGE IDs.**

2.2.1 CAN BUS TERMINATION

The CAN bus can be directly terminated from S2A by insert CAN harness cap:

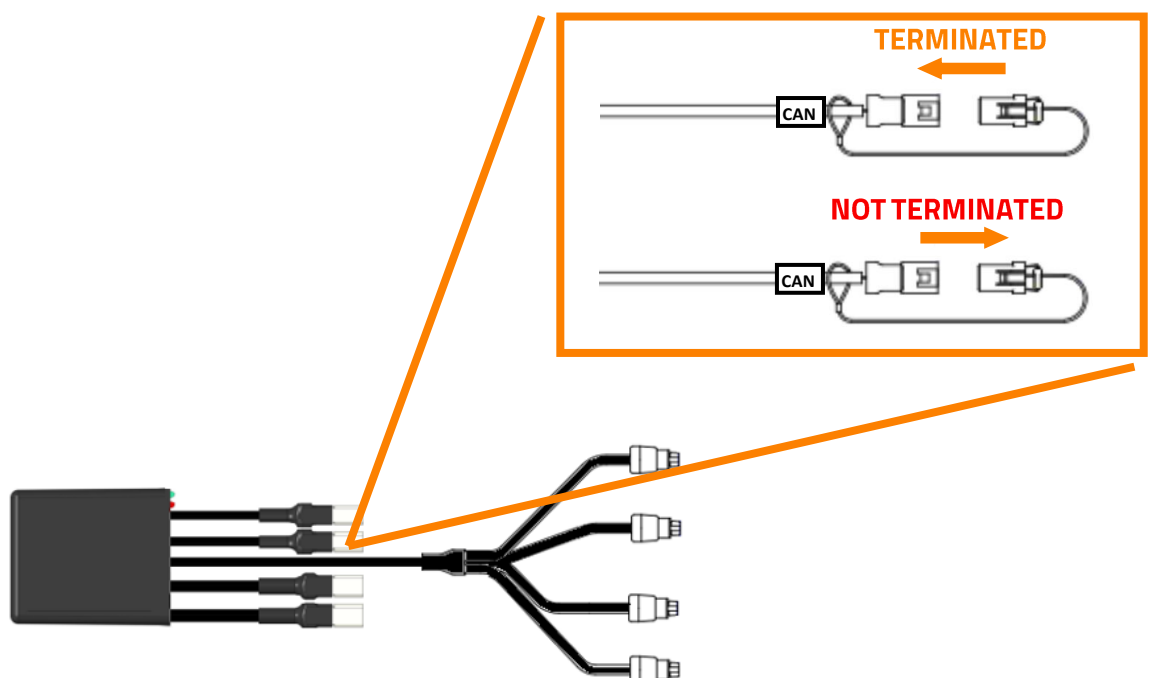

3 SYSTEM BEHAVIOR

Once connected to the power supply, S2A will start to send its input signal values over CAN bus in configured message IDs.

Two status LED s will be used for system diagnostic.

3.1 LEDs BEHAVIOUR

SYSTEM POWER UP		
LED	STATUS	DESCRIPTION
GREEN	ON	System boot
RED	ON	System boot

NORMAL CONDITION		
LED	STATUS	DESCRIPTION
GREEN	BLINK	Normal CAN activity
RED	OFF	-

CONDIZIONE DI ERRORE		
LED	STATUS	DESCRIPTION
GREEN	ON	System power up
RED	BLINK	CAN bus Error

If red LED stay ON check both CAN bus connection and S2A configuration.

3.2 STANDARD CAN CONFIGURATION

The standard configuration is shown in table below:

Bus Speed: 1Mb/s

Byte Order: Little Endian (INTEL)

Message TX rate: 200 Hz

CAN MESSAGE STRUCTURE				
ID (hex)	Start Bit	Bit length	Type	DESCRIZIONE
0x90	0	16	Unsigned	AN1 value (0...65535)
0x90	16	16	Unsigned	AN2 value (0...65535)
0x90	32	16	Unsigned	AN3 value (0...65535)
0x90	48	16	Unsigned	AN4 value (0...65535)
0x91	0	16	Unsigned	AN5 value (0...65535)
0x91	16	16	Unsigned	AN6 value (0...65535)
0x91	32	16	Unsigned	AN7 value (0...65535)
0x91	48	16	Unsigned	AN8 value (0...65535)
0x93	0	16	Unsigned	IC1 value (0...65535)
0x93	16	16	Unsigned	IC2 value (0...65535)
0x93	32	16	Unsigned	IC3 value (0...65535)
0x93	48	16	Unsigned	IC4 value (0...65535)

The relationship between input signal and CAN bus output is shown in table below:

CAN MESSAGES VALUES		
INPUT TYPE	PHYSICAL RANGE	MESSAGE RANGE
ANALOG (AN1...AN8)	0 – 5 V	0 - 65535
FREQUENCY (IC1...IC4)	0-20 kHz	0 - 20000

4 TECHNICAL DATA

4.1 SPECIFICATIONS

ELECTRICAL CHARACTERISTIC	
Main Power Supply	9-18V, typ. 12V
Output Regulated Voltage	5V at 70mA max
Current Consumption	typ. 100mA@12V (no sensor connected)

MECHANICAL CHARACTERISTIC	
Dimensions	18.5mm x 53mm x 62.25mm (without harness)
Weight	Approximately 130g
Housing materials	PA6-GF30 (30% Glass Reinforced, Heat Stabilized, Flame Retardant)
International Protection Code	IP67

TEMPERATURE RANGE	
Operating Temperature	-20°C / +70°C

IO PERIPHERALS	
Analog Inputs channels	6x single-ended (SAR) - resolution: 12bit (AN1-AN2-AN3-AN4-AN5-AN7)
	2x single-ended (SAR) - resolution: 10bit (AN6-AN8)
	voltage range: 0V-5V
Digital Inputs channels	4x frequency (max. input frequency 20KHz)
	voltage range: 0V-12V
System monitoring	2x device status LEDs

COMMUNICATIONS PORTS	
CAN port	1x CAN 2.0A/B (up to 1 Mbits/s) – bus termination by connector cap
Serial port	1x RS232 (only for configuration)

STANDARD HARNESS AND CONNECTORS	
Main cable (MAIN)	8 poles JST connector (08T-JWPF-VSLE-D)
Communication cable (CAN)	8 poles JST connector (08T-JWPF-VSLE-D)
Input cable analog AN1-4	4 x 3 poles Binder (09-9748-70-03)
Input cable analog AN5-8 (EXP-1)	6 poles JST connector (06R-JWPF-VSLE-D)
Input cable analog IC1-4 (EXP-2)	6 poles JST connector (06R-JWPF-VSLE-D)

OTHER FEATURES	
TX CAN messages	broadcast
TX CAN messages data rate	up to 200Hz
TX CAN IDs messages	3x message ID

4.2 DIMENSIONS

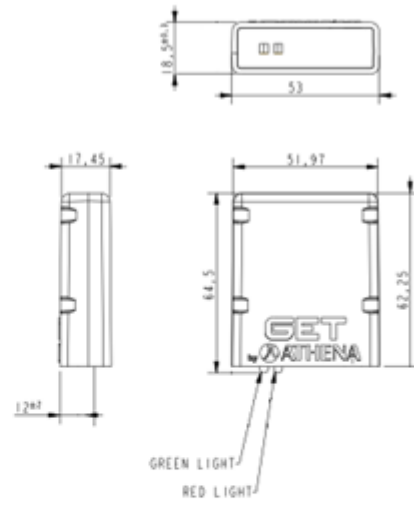

4.3 HARNESS

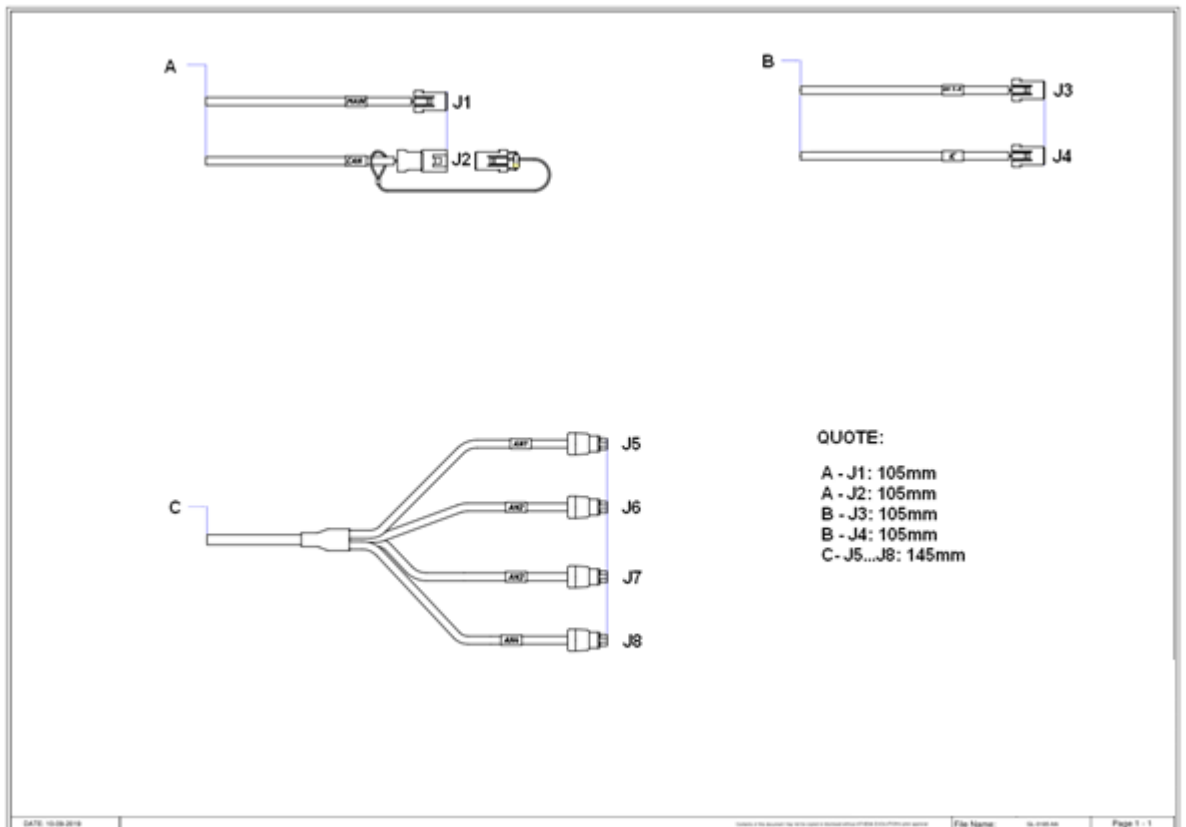

4.4 CONNECTORS PINOUT

4.4.1 MAIN CONNECTOR

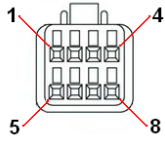

MAIN Connector
front view
(wiring get out from rear part)

MAIN connector Pinout		
1	VPWR	Power supply Positive
2	GNDPOW	Power supply Ground
3	CANOL	CANL signal
4	CANOH	CANH signal
5	GNDSEN	Auxiliary power and analog/frequency input ground
6	RX	Programming RX signal
7	TX	Programming TX signal
8	PRG	Reserved

4.4.2 CAN CONNECTOR

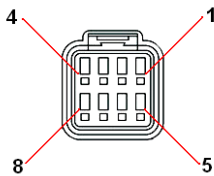

CAN Connector
front view
(wiring get out from rear part)

CAN connector Pinout		
1	VPWR	Power supply Positive
2	GNDPOW	Power supply Ground
3	CANOL	CANL signal
4	CANOH	CANH signal
5	-	Not connected
6	-	Not connected
7	-	Not connected
8	-	Not connected

4.4.3 EXP-1 CONNECTOR

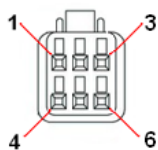

EXP-1 connector

Front view

(wiring get out from rear part)

EXP-1 connector Pinout		
1	5VAUX	Auxiliary power out (5VDC – 70mA max.)
2	GNDSEN	Auxiliary power and analog/frequency input ground
3	AN5	Analog input AN5 signal (0-5V)
4	AN6	Analog input AN6 signal (0-5V)
5	AN7	Analog input AN7 signal (0-5V)
6	AN8	Analog input AN8 signal (0-5V)

4.4.4 EXP-2 CONNECTOR

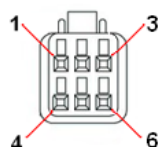

EXP-2 Connector

front view

(wiring get out from rear part)

EXP-2 connector Pinout		
1	VPWR	Power supply Positive
2	GNDSEN	Auxiliary power and analog/frequency input ground
3	IC3	Frequency input IC3 signal (0-12V)
4	IC4	Frequency input IC4 signal (0-12V)
5	IC1	Frequency input IC1 signal (0-12V)
6	IC2	Frequency input IC2 signal (0-12V)

4.4.5 BINDER CONNECTORS (AN1, AN2, AN3, AN4 INPUTS)

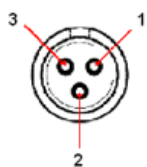

BINDER Connector

front view

(wiring get out from rear part)

Binder connector Pinout		
1	5VAUX	Alimentazione ausiliaria (5VDC – 70mA max.)
2	SIGNAL	Input signal (0-5V)
3	GNDSEN	Auxiliary power and analog/frequency input ground

4.5 OPTIONALS CABLE (SOLD SEPARATELY)

4.5.1 GL-196-AN (AN5, AN6, AN7, AN8 INPUTS)

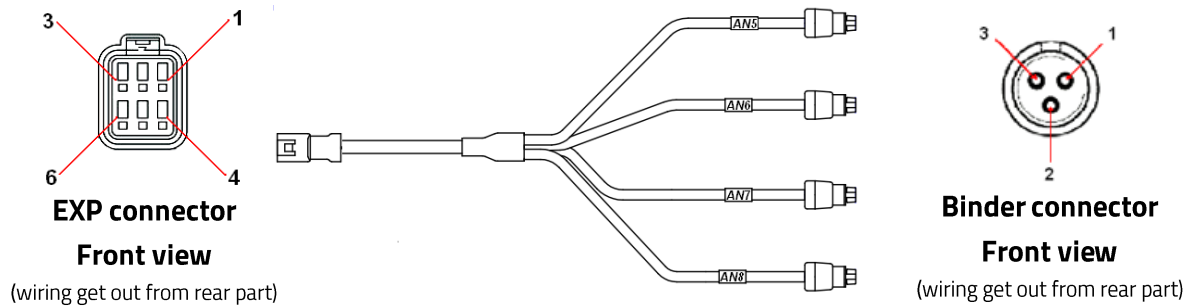

EXP connector Pinout		
1	5VAUX	Auxiliary power out (5VDC – 70mA max.)
2	GNDSEN	Auxiliary power and analog/frequency input ground
3	AN5	Analog input AN5 signal (0-5V)
4	AN6	Analog input AN6 signal (0-5V)
5	AN7	Analog input AN7 signal (0-5V)
6	AN8	Analog input AN8 signal (0-5V)

Binder connector Pinout		
1	5VAUX	Alimentazione ausiliaria (5VDC – 70mA max.)
2	SIGNAL	Segnale ingresso analogico
3	GNDSEN	Auxiliary power and analog/frequency input ground

4.5.2 GL-196-IC (IC1, IC2, IC3, IC4 INPUTS)

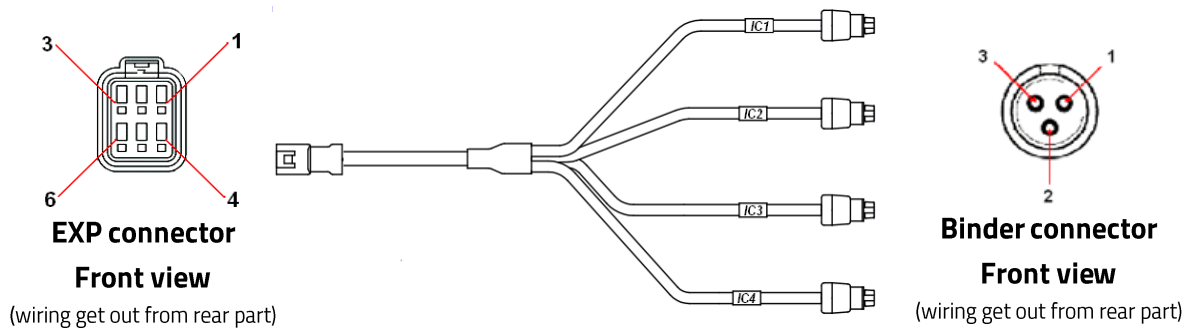

EXP connector Pinout		
1	VPWR	Positive Power supply
2	GNDSEN	Auxiliary power and analog/frequency input ground
3	IC3	Frequency input IC3 signal (0-12V)
4	IC4	Frequency input IC4 signal (0-12V)
5	IC1	Frequency input IC1 signal (0-12V)
6	IC2	Frequency input IC2 signal (0-12V)

Binder connector Pinout		
1	VPWR	Positive Power supply
2	SIGNAL	Frequency input signal (0-12V)
3	GNDSEN	Auxiliary power and analog/frequency input ground

5 MOST COMMON SENSORS/SEGNALE CLASSIFICATION

SENSOR / SEGNALE	TYPE	S2A INPUT
SPEED	Frequency	IC1...IC4
ENGINE REVOLUTIONS (RPM)	Frequency	IC1...IC4
PRESSURE	Analog	AN1...AN8
TEMPERATURE	Analog	AN1...AN8
LAMBDA (O2 sensor)	Analog	AN1...AN8
THROTTLE POTENTIOMETER (TPS)	Analog	AN1...AN8
SUSPENSION POTENTIOMETER	Analog	AN1...AN8

6 WIRING EXAMPLES

Following chapters illustrate some examples of S2A connections:

6.1 STAND-ALONE CONNECTION

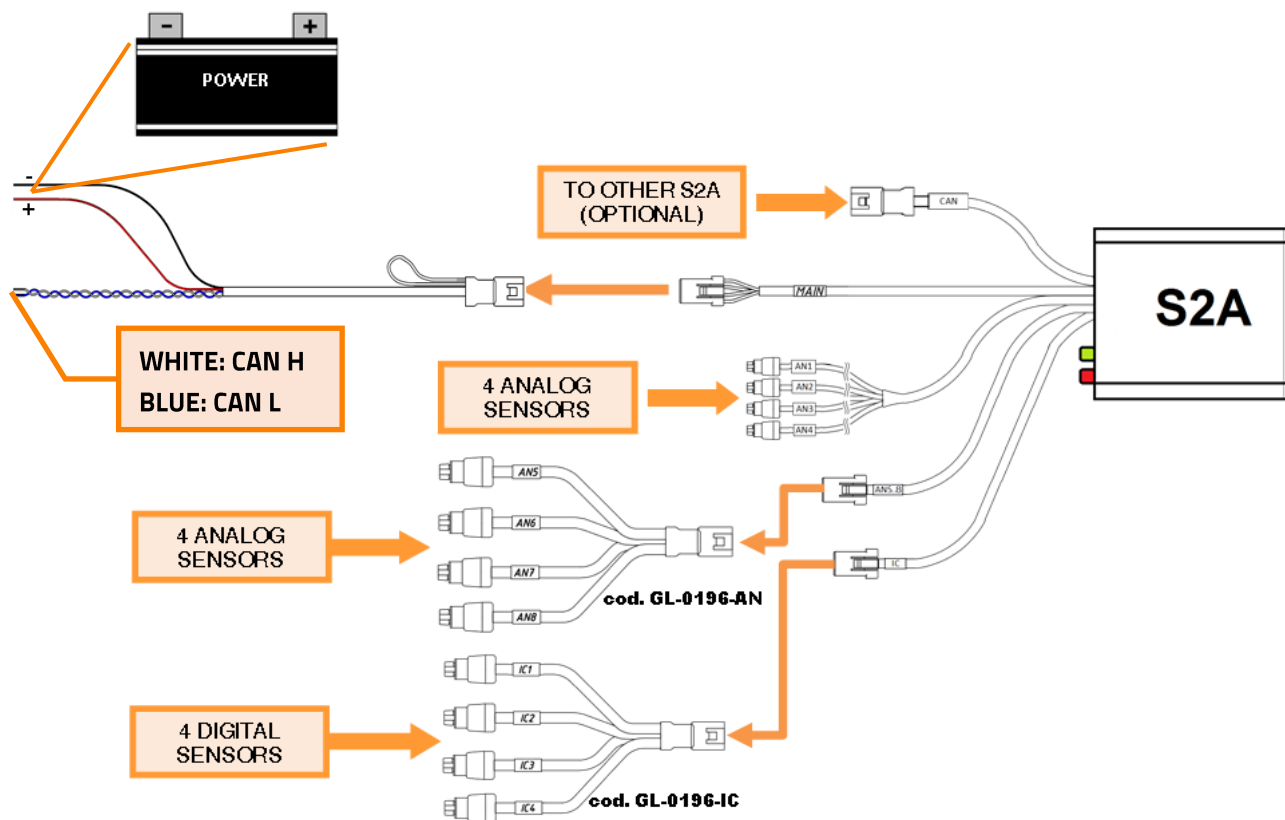

WARNING: CHECK CAN BUS TERMINATION.

6.2 SL1 - S2A CONNECTION

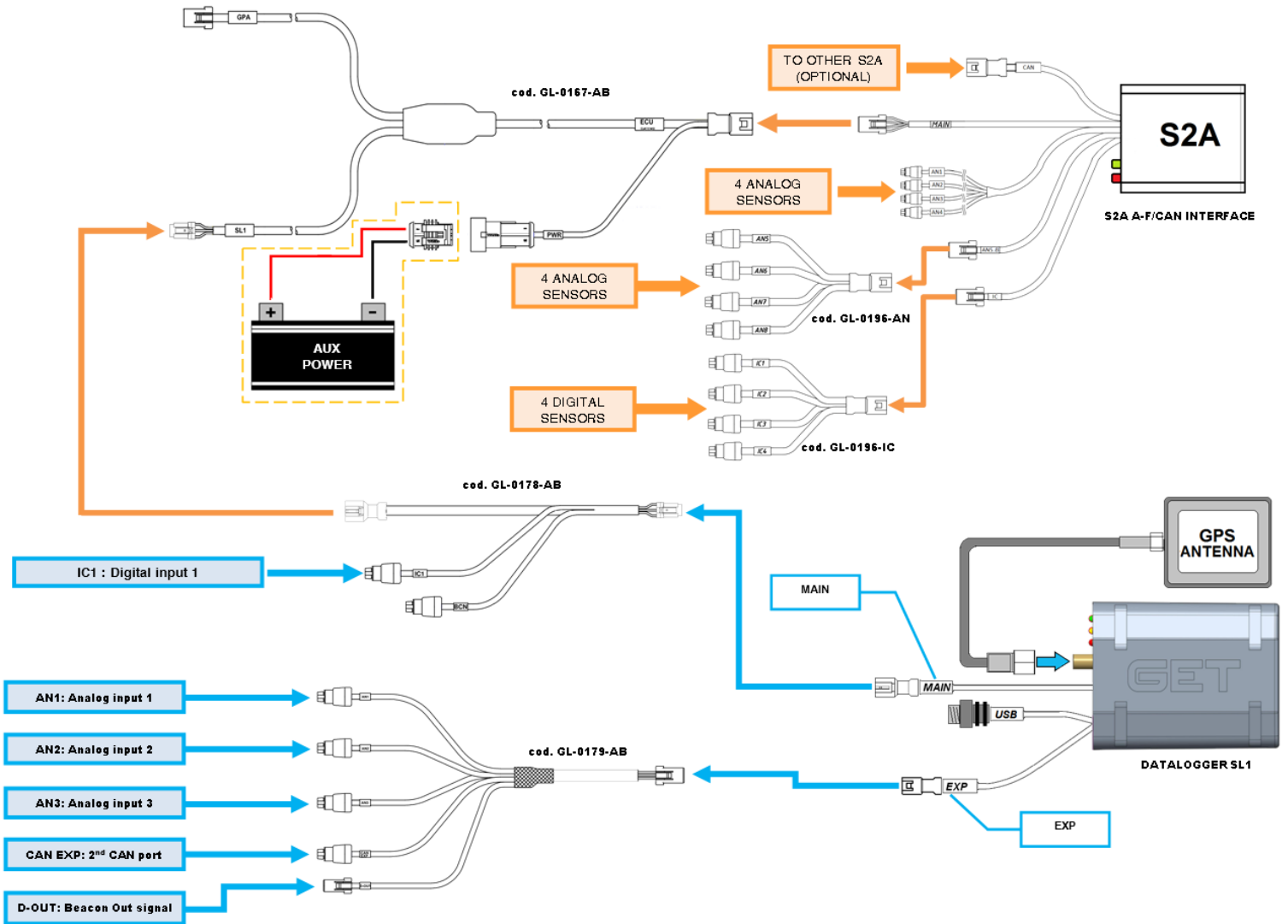

6.3 SL1 – ECU GET - S2A CONNECTION

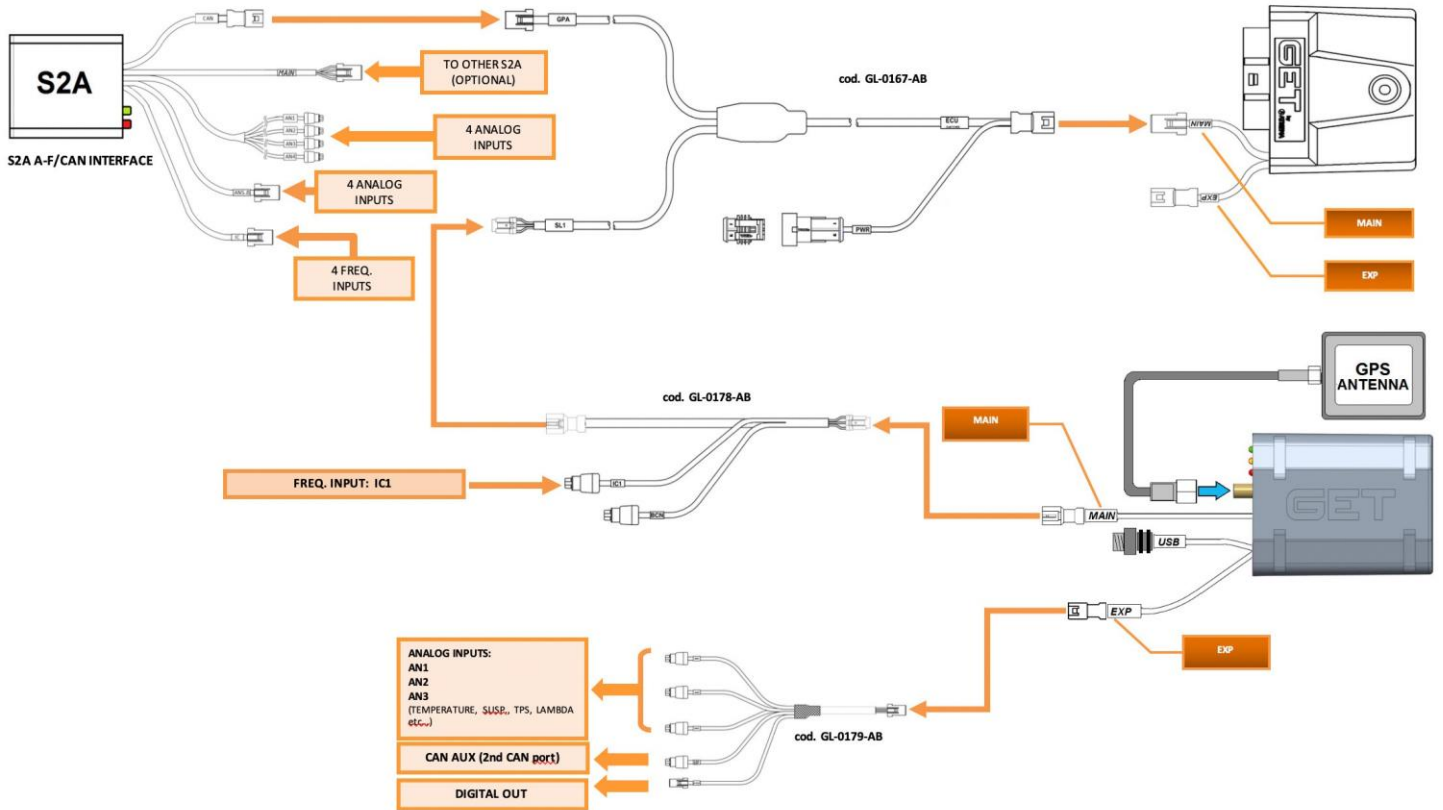

6.4 SL1 - S2A - D30 DASH CONNECTION

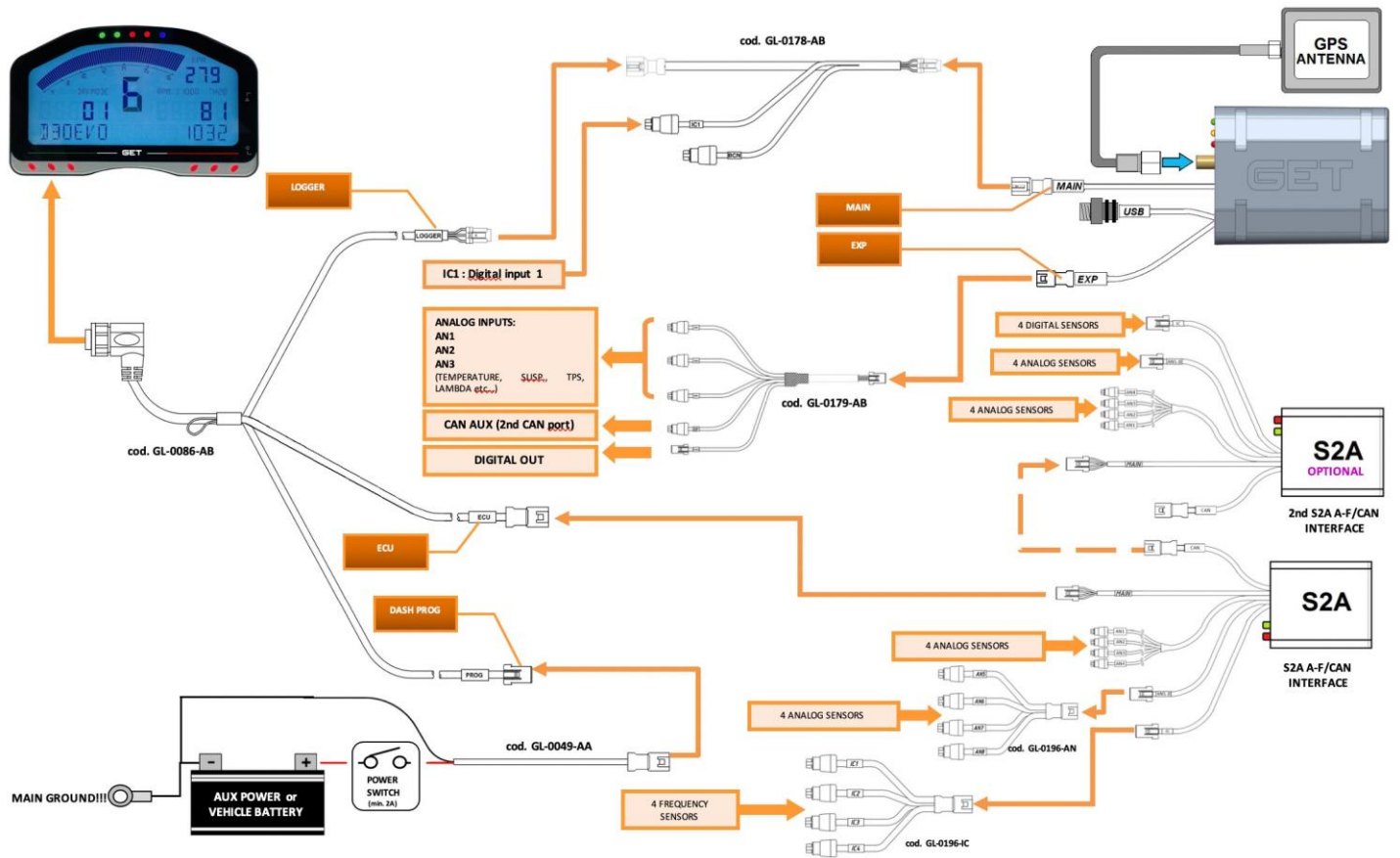

7

GLOSSARY

AN –Analog input.

CAN – Controller Area Network.

FS – Full-scale.

LED – Light Emitting Diode.

IC – frequency Input (Input Capture).

RPM – Revolution per Minute.

TPS – Throttle position sensor.



www.athena.eu



sales.get@athena.eu